

Egate-100

Gigabit Ethernet over TDM Aggregation Gateway



- Central site Ethernet over TDM aggregates Gigabit Ethernet traffic over three channelized T3 Ports or TDM fiber interface
- Combines data streams from multiple remote sites of varying link capacities and encapsulation technologies
- Gigabit port protection and dual power supply ensures higher service uptime
- Priority and queuing schemes allow differentiated services on the same link
- Transports Ethernet services transparently.



Egate-100 is a Gigabit Ethernet over TDM aggregation gateway that interconnects packet networks via PDH access. The device features next-generation Ethernet over PDH encapsulation and bonding capabilities, including standard protocol generic framing procedure (GFP, G-8040), virtual concatenation (VCAT G.7043), and link capacity adjustment scheme (LCAS G.7042).]

Ethernet traffic over E1/T1 lines or T3 links is aggregated and transferred to the packet-switched network via the unit's Gigabit Ethernet ports.

The device provides the following aggregations (depending on the configuration):

- Up to 42 remote LANs over bonded n x E1/T1 lines for GFP-VCAT and 60 remote LANs for MLPPP
- Up to 84 remote LANs over T1 circuits
- Up to 126 remote LANs over fractional E1/T1 circuits.

Due to its service scalability, small footprint and low power consumption, Egate-100 significantly reduces equipment costs and simplifies network operation.

Egate-100 is certified by the Metro Ethernet Forum (MEF) for MEF 9 Ethernet Private Line (EPL) service.

APPLICATIONS

Typically deployed at a central location, Egate-100 aggregates user Ethernet traffic received from remote devices (such as RAD's RICI, FCD, or ASMI, or third-party devices), thus completing a full access solution from the service provider's central site to the customer premises.

Other typical applications include:

- IP DSLAM and IP base station traffic backhauling
- WiMAX BTS traffic backhauling
- Ethernet private line/LAN services
- Backhauling of network management traffic

Aggregation of Ethernet traffic over PDH wireless links.

ETHERNET OVER TDM

Encapsulation Protocols

Egate-100 transports Ethernet over PDH infrastructure via the following NG-PDH technologies:

- GFP (ITU-T G.8040, G.7041/Y.1303) VCAT (ITU-T G.7043)
- LCAS (ITU-T G.7042)
- RAD proprietary HDLC compatible with RAD products
- PPP/BCP (RFC 1661, RFC 3518)
- MLPPP (BCP) according to RFC 1661, RFC 1990, RFC 3518
- L2CP packets – transported transparently.

Flows

Egate-100 provides traffic flow classification and policing for network ingress traffic. This enables operators to differentiate services using classification methods, police the traffic and enforce SLA per service.

Incoming traffic from the Gigabit Ethernet port is classified and mapped to Ethernet flows using a variety of classification methods, such as CE VLAN-ID, VLAN priority, DSCP and IP-precedence.

Egate-100

Gigabit Ethernet over TDM Aggregation Gateway

Policers can be applied per flow and operate according to the dual bucket mechanism (CIR + CBS + EIR + EBS).

OAM

Egate-100 provides single segment (link) OAM based on 802.3-2005 (formerly 802.3ah), including discovery, continuity check, and remote fault indication. OAM is supported over the PDH logical links.

Quality of Service (QoS)

Egate-100 provides traffic flow classification and policing for network ingress traffic. This enables operators to differentiate services using classification methods, police the traffic and enforce SLA per service.

Incoming traffic from the Gigabit Ethernet port is classified and mapped to Ethernet flows using a variety of classification methods, such as CE VLAN-ID, VLAN priority, DSCP and IP-precedence.

Policers can be applied per flow and operate according to the dual bucket mechanism (CIR + CBS + EIR + EBS).

Rate limitation can also be applied per bridge port to shape the outgoing traffic. Different service rates can be provided with TDM-based fractional E1/T1, n ´ E1/T1 granularity.

BRIDGE

Egate-100 acts as a bridge in a TDM environment, enabling service providers to achieve seamless interconnection between customers using the TDM network and customers using the packet network, maintaining the same service level attributes.

VLAN tagging and double tagging (Q-in-Q) allows adding a provider's VLAN to enable transparent LAN services in parallel to user VLAN settings.

The split horizon mechanism prevents network congestion and Ethernet loops by preventing traffic from being switched between local bridge ports.

S-TAG per 802.1ad for VLAN tagged frames, as well as proprietary Ethertype values, are supported.

In VLAN-aware mode (IVL), frames are forwarded according to VLAN tags and MAC address. This allows defining different user traffic domains in order to create point-to-point (E-Line) or point-to-multipoint (E-LAN) topologies. A VLAN tunnel can be created for separating management and user traffic.

In a typical service provisioning structure, Egate-100 links between users connected to a packet-switched network and users connected to a TDM network.

Virtual channels are established between the far-end users by tagging separate user

traffic channels with VLANs. These virtual channels enable transparent forwarding of all user traffic. In addition, all devices are managed over a separate dedicated VLAN, with secure separation between user traffic and management traffic.

RESILIENCY

Aggregating traffic from many remote sites, Egate-100 increases the reliability of service and ensures continued operation. The device supports:

Gigabit Ethernet port redundancy, based on standard link aggregation protocol 802.3ad

TIMING

Simple Network Time Protocol (SNTP) is used to synchronize to an accurate time from an NTP server at user selectable intervals.

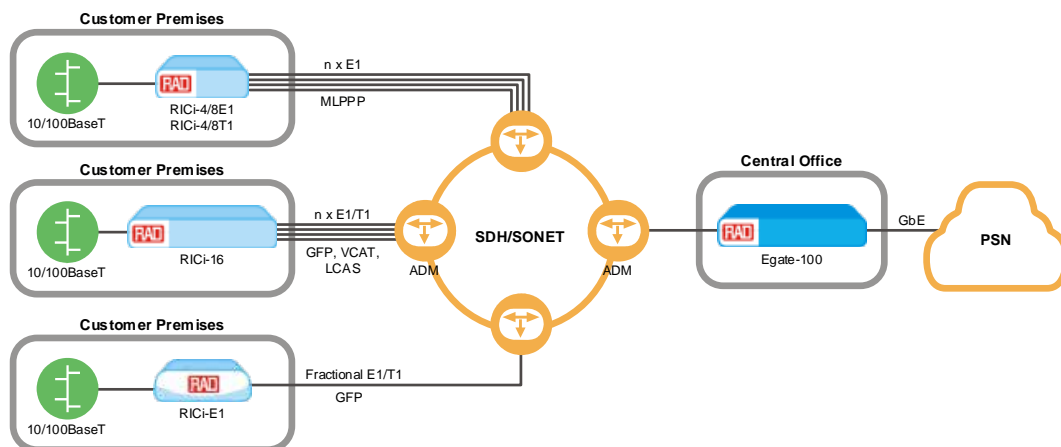

Figure 1. Aggregating Ethernet Traffic over E1/T1 Lines

MONITORING AND DIAGNOSTICS

Comprehensive diagnostic and performance monitoring capabilities include:

- Ping test for checking IP connectivity
- PRBS Test over E1 or T1 lines
- Statistics and alarms for the physical Ethernet interfaces, TDM ports, bridge ports, and logical layer.

System logs are forwarded to the network according to predefined criteria.

Egate-100 provides single segment (link) OAM based on 802.3-2005 (formerly 802.3ah), including discovery, continuity check, and remote fault indication. OAM is supported over the PDH logical links.

1/T1 loops are immediately detected when they occur and the bridge port is closed to avoid Ethernet loops. Once the E1/T1 loops are released, normal operation resumes.

MANAGEMENT AND SECURITY

The unit can be managed using various ports and applications:

- Local management via an ASCII terminal connected to the RS-232 port
- Out-of-band management via one of the GbE ports
- Remote inband management via one of the Gigabit Ethernet ports using Telnet, Web browser, or RADview, RAD's SNMP-based EMS.

A dedicated VLAN can be used to secure the management traffic and separate it from user traffic.

The following security mechanisms are provided:

- Access control for SNMPv3, Telnet, and Web-based management interface for granting access only to users that appear in the manager list
- SSL/SSH for Telnet and secure Web access.
- RADIUS protocol for password management and user authentication.

OPERATION AND MAINTENANCE

Egate-100 provides single-segment (link) OAM based on 802.3-2005 (formerly 802.3ah), including discovery, continuity check, and remote fault indication. OAM is supported over the PDH logical links.

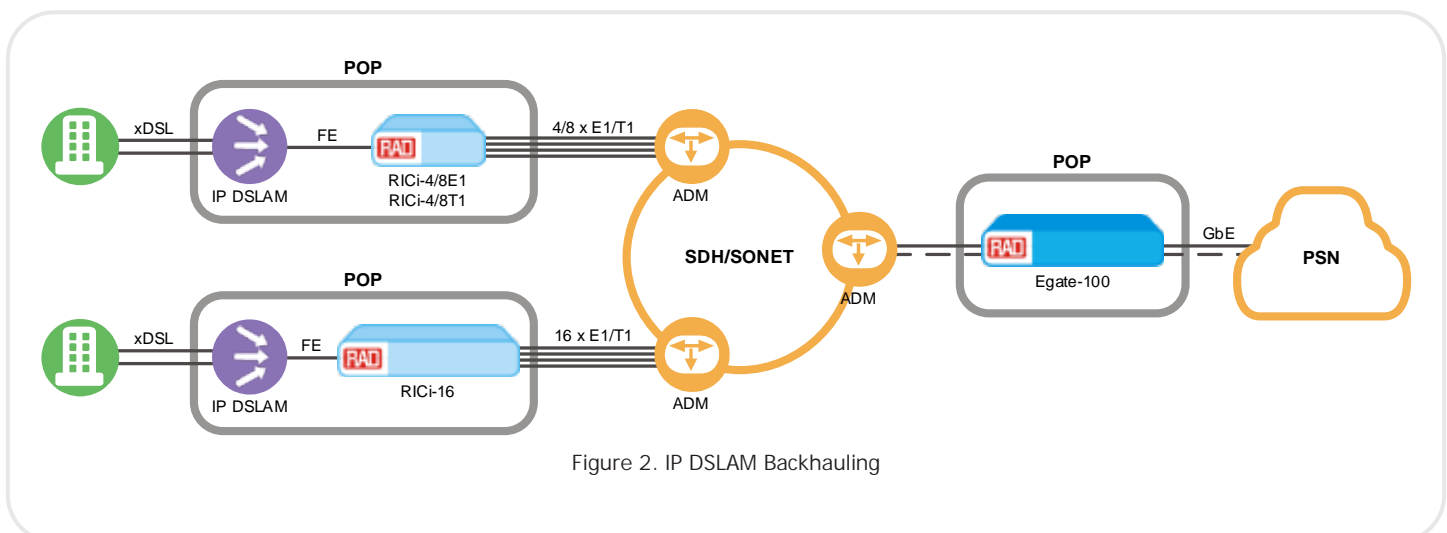

Figure 2. IP DSLAM Backhauling

Egate-100

Gigabit Ethernet over TDM Aggregation Gateway

Specifications

CAPACITY

155Mbps

TDM INTERFACE

Number of Ports

2 (1+1)

Operation Mode

TDM

SFP Transceivers

For full details, see the SFP Transceivers data sheet at www.rad.com

Connector

SFP slot (for transceivers, see *Ordering*)

T3 INTERFACE

Number of Ports

3

Compliance

T1.107, GR-499-CORE

Data Rate

44.736 Mbps

Mapping

28 T1s mapped into T3 (via M13 mux)

Framing

M23

C-Bit parity

Line Interface

75W coax up to 100m (328 ft)

GIGABIT ETHERNET INTERFACE

Number of Ports

2

Interface Type

1000BaseSx, 1000BaseLx, or 10/100/1000BaseT

Compliance

Relevant sections of IEEE 802.3

Data Rate

Optical: 1000 Mbps

Electrical: 10/100/1000 Mbps

Max Frame Size

1600 bytes

Gigabit Ethernet Redundancy

Link aggregation according to IEEE 802.3ad

SFP Transceivers

For full details, see the SFP Transceivers data sheet at www.rad.com

Connector

Optical :

SFP slot

(for transceivers, see *Ordering*)

Electrical : RJ-45

Electrical Cable Type

Cat. 5

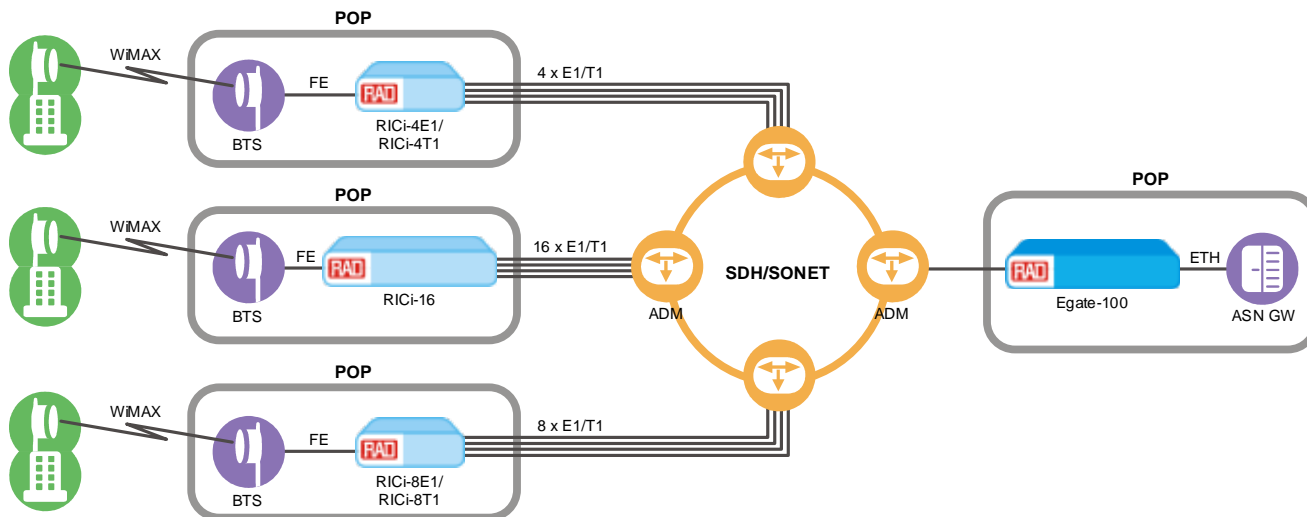

Figure 3. WiMAX BTS Traffic Backhauling

INTERNAL BRIDGE

Operation Mode

VLAN-aware, VLAN-unaware learning bridge

Number of VLANs

Up to 1024

Compliance

Relevant sections of 802.1Q

LAN Table

Up to 64,000 MAC addresses (learned)

MANAGEMENT PORT

Control Port

Interface: V.24/RS-232 DCE

Connector: 9-pin D-type, female (DB-9)

Data rate: 9.6, 19.2, 38.4, 57.6 or 115.2 kbps

GENERAL

Indicators

POWER:

- On (green): Power supply performing properly
- Off (red): Power supply error or not connected to power

ALM (red):

- On: Interface (GbE) or system error
- Off: No error

ACT (yellow):

- Blinking: Ethernet frame received or sent within the last second
- Off: No frame received or sent within the last second

TDM Option

SYNC (green):

- On: TDM port is synchronized
- Off: LOS, LOF

T3 Option

SYNC (green):

- On: T3 port is synchronized
- Off: LOS

Power

AC: 100–240 VAC (±10%), 50/60 Hz

DC: 48/60 VDC nominal (40–72 VDC)

Power Consumption

40W max

Physical

Height: 43.7 mm (1.7 in) 1U

Width: 440 mm (17.3 in)

Depth: 240 mm (9.4 in)

Weight: Single power supply: 3.5 kg (7.7 lb)

Dual power supply: 4.0 kg (8.8 lb)

NEBS level 3, types 2 and 4 compliant

Note: By default, the T3 option is NEBS-3 compliant.

Environment

Temperature: 0°–50°C (32°–122°F)

Humidity: Up to 90%, non-condensing

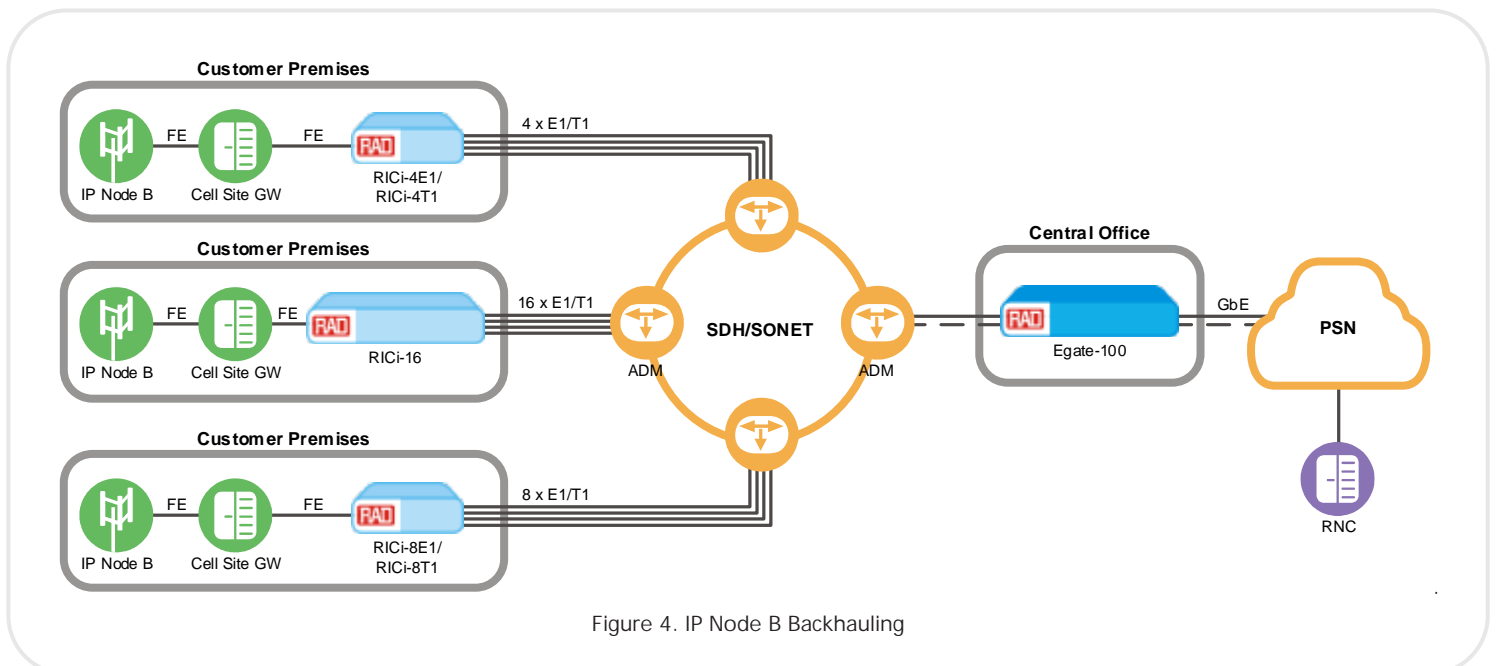

Egate-100

Gigabit Ethernet over TDM Aggregation Gateway

Ordering

RECOMMENDED CONFIGURATIONS

EGATE-100/ACR/NULL/UTP/UTP/DIS

Dual 100 to 230 VAC power supply, one empty SFP slot, two built-in 10/100/1000BaseT Ethernet ports with RJ-45 connectors, activation of 30 E1 and 42 T1 ports

EGATE-100/ACR/NULL/UTP/UTP/FULL

Dual 100 to 230 VAC power supply, one empty SFP slot, two built-in 10/100/1000BaseT Ethernet ports with RJ-45 connectors, activation of 63 E1 and 84 T1 ports

EGATE-100/ACR/NULL/NULL/NULL/DIS

Dual 100 to 230 VAC power supply, six empty SFP slots, activation of 30 E1 and 42 T1 ports

EGATE-100/ACR/NULL/NULL/NULL/FULL

Dual 100 to 230 VAC power supply, six empty SFP slots, activation of 63 E1 and 84 T1 ports

EGATE-100/48R/NULL/UTP/UTP/FULL

48 VDC power supply, one empty SFP slot, two built-in 10/100/1000BaseT Ethernet ports with RJ-45 connectors, activation of 63 E1 and 84 T1 ports

EGATE-100/48R/NULL/UTP/NULL/FULL

48 VDC power supply, one empty SFP slot, built-in 10/100/1000BaseT Ethernet ports with RJ connector, activation of 63 E1 and 84 T1 ports

EGATE-100/48R/NULL/NULL/NULL/FULL

48 VDC power supply, six empty SFP slots, activation of 63 E1 and 84 T1 ports

SPECIAL CONFIGURATIONS

Please contact your local RAD partner for additional configuration options

SUPPLIED ACCESSORIES

AC power cord for AC unit

DC connection kit (if a DC powered unit is ordered)

CBL-DB9F-DB9M-STR

Control port cable

RM-34

Hardware kit for mounting one Egate-100 unit in a 19-inch rack

OPTIONAL ACCESSORIES

WM-34

Hardware kit for mounting one Egate-100 unit on a wall