

ETX-1300

Gigabit Ethernet Aggregation Switch



- Aggregation of 32 fiber optic or electrical Fast Ethernet interfaces into Gigabit Ethernet Network
- Link resiliency and service continuity, using Link Aggregation (IEEE 802.3ad) and Ethernet ring protection (G.8032)
- Quality of Service with queue mapping per port, P-bit, DSCP, or ToS
- Ethernet bridging and switching with VLAN-aware, VLAN-unaware, and VLAN stacking modes
- Link-level Ethernet OAM per IEEE 802.3ah for network monitoring and troubleshooting

ETX-1300 is a compact Ethernet aggregation switch with four Gigabit Ethernet ports and 32 Fast Ethernet ports providing resilient network architecture with G.8032 ring support or 802.3ad linear protection. Featuring non-blocking architecture, the device enables wire-speed data transmission for Layer-2 Ethernet connectivity.

ETX-1300 introduces a robust, carrier class design with redundant extractable power supplies, external alarm port and clock interfaces for input or output clock synchronization.

ETHERNET

ETX-1300 features the following PSN ports:

- Four Gigabit Ethernet ports with SFP-UTP combo connectors
- 32 Fast Ethernet ports with fiber optic SFP or UTP connectors.

Forwarding

ETX-1300 includes an internal bridge, operating in VLAN-aware and VLAN-unaware modes.

VLAN stacking can be used for traffic separation between different users or services, by defining a service provider VLAN ID per customer or service. When

VLAN stacking is used, a service provider VLAN tag is added to the user traffic and removed from network traffic. Both service provider VLAN ID and service provider VLAN priority can be defined.

Classification

Policing and classification of the traffic flows are performed between any ingress and any egress Ethernet port of the device. ETX-1300 monitors traffic with specified flow parameters, allocates bandwidth, forwards traffic to different queues according to classification parameters etc.

OAM

ETX-1300 supports link level OAM per IEEE 802.3ah enabling link management including OAM discovery, link monitoring, remote fault detection, and remote loopback control operations.

Traffic Management

User traffic can be queued and prioritized according to VLAN priority and ToS/Diffserv.

Ingress and egress rate can be limited per user and network ports.



Smart SFPs

When equipped with a removable MiRiCi-E3T3 module (ver. 2.5), a fiber FE port can operate as an E3 or T3 port, forwarding LAN packets to TDM-based WAN. When operating in the T3 mode, MiRiCi-E3T3 modules are fully controllable via ETX-1300 management application.

Note: ETX-1300 equipped with the AC or 48 power supply modules supports up to 16 MiRiCi-E3T3 units. When equipped with two high-power ACHP or 48HP power supply modules, ETX-1300 can host up to 32 MiRiCi-E3T3 units.

RESILIENCY

LAG

Link aggregation is performed as per 802.3ad (with or without LACP). This enables operators to use up to four Ethernet links as a single virtual interface, sharing traffic load and providing link resiliency.

Ethernet Ring Protection

Ethernet Ring Protection technology per G.8032 provides resilient network connection over ring architecture and rapid service restoration.

ETX-1300

Gigabit Ethernet Aggregation Switch

TIMING AND SYNCHRONIZATION

ETX-1300 features a flexible clock mechanism using external and internal timing signals coming from:

- Timing from GbE ports (Sync-E)
- External station clock source via station clock port, providing out-of-band synchronization.

MANAGEMENT AND SECURITY

The unit can be managed using different ports and applications:

- Local out-of-band management via a terminal connected to the RS-232 port
- Remote out-of-band management via the dedicated 10/100BaseT port
- Remote inband management via the GbE or FE interface. Remote management is performed using Telnet or RADview, RAD's SNMP-based EMS.

OPERATION AND MAINTENANCE

Software download is available via local terminal using XMODEM/YMODEM, or remotely using TFTP/FTP.

Syslog

ETX-1300 uses the Syslog protocol to generate and transport event notifications over IP networks to the central Syslog server. The Syslog operation complies with the RFC 3164 requirements.

MONITORING AND DIAGNOSTICS

Comprehensive monitoring and diagnostic capabilities include port status indication and statistic counters for Gigabit Ethernet interfaces.

Alarms

The device includes a dry-contact connector for reporting alarms to external equipment. The connector also has an external alarm input for monitoring external sensors.

For diagnostic purposes, ETX-1300 maintains a cyclic event log file that stores up to 2048 time-stamped events and a real-time current alarm list.

Self-Test

An internal built-in test (BIT) performed after power-up checks the internal circuitry of the unit. The results of the test are visible via the local terminal.

Applications

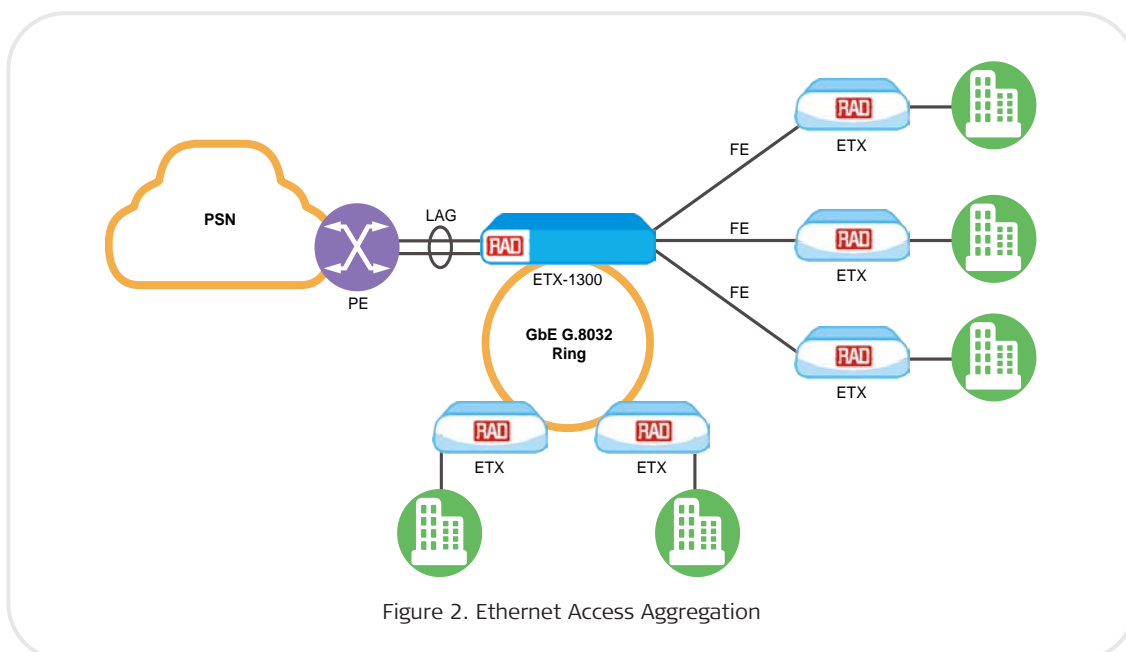

Figure 2. Ethernet Access Aggregation

Specifications

GIGABIT ETHERNET INTERFACES

Number of Ports

4

Type

1000BaseSX, 1000BaseLX,
10/100/1000BaseT

Compliance

IEEE 802.3, 802.1, 802.1 Q

Connector

SFP-UTP combo

FAST ETHERNET INTERFACES

Number of Ports

32

Type

100BaseFX, 100BaseLX10, 100BaseBX10,
10/100BaseT

Connector

Fiber optic (via SFP) or built-in RJ-45

BRIDGE

Type

VLAN-aware, VLAN-unaware

Filtering and Forwarding

MAC learning and filtering

FLAWS

Ingress port, egress port, drop action,
traffic class

Policer profile: CIR+CBS

Classification rules: VLAN, VLAN + P-bit, IP
ToS, IP DSCP

QUALITY OF SERVICE (QOS)

Rate Limitation

Ingress, ingress storm, egress

Scheduling

HQP, WRR

Classification

VLAN, P-bit, IP Precedence, IP DSCP

MANAGEMENT

Authentication

RADIUS client

Control Port

Interface: V.24/RS-232 DCE
Connector: 9-pin D-type, female

Ethernet Management Port

Interface: 10/100/1000BaseT
Connector: RJ-45

Management Options

SNMPv1, SNMPv2c, SNMPv3

Telnet

ASCII terminal

TIMING

Synchronous Ethernet

Per ITU-T G.8261

External Clock

2.048 Mbps input/output via two BNC,
unbalanced (75 Ω) connectors, G.703,
HDB3/AMI code

2.048 Mbps via dedicated RJ-45 balanced
120 connector, G.703, HDB3/AMI code,
2048 kHz squarewave (RS-485 electrical
levels)

RESILIENCY

Link Aggregation

Up to 4 GbE ports only, with or without
LACP

Ethernet Ring

Per G.8032

DIAGNOSTICS

Connectivity Verification Tools

Ping, traceroute, Virtual Cable Test (VCT)

External Alarm Interface

Via dedicated DB-9 female connector

GENERAL

Indicators

LINK (green) – Ethernet link status

ACT (yellow) – Ethernet activity status

TST (yellow) – Test status

ALM (red) – Alarm status

PS1 (green) – Power supply status

PS2 (green) – Power supply 2 status

Power

AC: 100 to 240 VAC (115/230 VAC nominal),
50/60 Hz

DC: 40 to 72 VDC (48 or 60 VDC nominal)

Power Consumption

75W max

Physical

Height: 43 mm (1.7 in)

Width: 440 mm (17.5 in)

Depth: 350 mm (13.7 in)

Weight: 5 kg (11 lb)

Environment

Temperature: 0 to 50°C (32 to 122°F)

Humidity: Up to 90%, non-condensing

ETX-1300

Gigabit Ethernet Aggregation Switch

Ordering

RECOMMENDED CONFIGURATIONS

ETX-1300/48R/32N

Gigabit Ethernet aggregation switch,
redundant -48 VDC power supply,
32 empty SFP slots

ETX-1300/48R/32UTP

Gigabit Ethernet aggregation switch,
redundant -48 VDC power supply,
32 10/100BaseT UTP ports

ETX-1300/ACR/32N

Gigabit Ethernet aggregation switch,
redundant AC power supply, 32 empty SFP
slots

ETX-1300/ACR/32UTP

Gigabit Ethernet aggregation switch,
redundant AC power supply,
32 10/100BaseT UTP ports

SPECIAL CONFIGURATIONS

Please contact your local RAD partner for
additional configuration options

SUPPLIED ACCESSORIES

Power cord

DC power connection kit

RM-34

Hardware kit for mounting one ETX-1300
unit into a 19-inch rack

OPTIONAL ACCESSORIES

ETX-1300-PS/@

Power supply and fan module

@ Power supply:

AC	100 to 240 VAC
48	-48 VDC

CBL-DB9F-DB9M-STR Control
port cable

Pulse Supply
909 Ridgebrook Road., Sparks, Maryland
21152, USA TEL : +1-410-583-1701
FAX : +1-410-583-1704
E-mail: sales@pulsesupply.com
<https://www.pulsesupply.com/rad>
www.pulsesupply.com/rad

